

Implementation of Model Radar for Target Identification Using AT89S52 Microcontroller

Preeti Pannu

Assistant Professor
Department of ECE
S.R.M. University, NCR Campus
Modinagar.

Ananya Maheshwari, Sahil Mishra

B.Tech Student
Department of ECE
S.R.M. University, NCR Campus
Modinagar.

ABSTRACT:

Radar is an object detection system which uses electromagnetic waves specifically radio waves — to determine the range, altitude, direction, or speed of both moving and fixed objects. The radar dish, or antenna (parabolic), transmits pulses of radio waves or microwaves which bounce off any object in their path. The object returns a tiny part of the wave's energy to a dish or antenna which is usually located at the same site as the transmitter. This project is used to identify the direction of the target from which it is coming and position of the object. This project uses AT89S52 Microcontroller which is interfaced with Radar Target Identifier system has an array of IR sensor pairs. These IR sensors are keeping track with the target in all the directions. If the target is found to be moved in any direction and then it gives a control signal to the microcontroller and the status is displayed on the LCD for user identification. This project uses regulated 5V, 500mA power supply. 7805 three terminal voltage regulator is used for voltage regulation. Bridge type full wave rectifier is used to rectify the ac output of secondary of 230/12V step down transformer.

KEYWORDS: Radio waves, Parabolic Antenna, Microcontroller, IR sensors, Full wave rectifier, Voltage regulator, Radar Target Identifier.

1. INTRODUCTION:

The main objective of this project is identifying the radar target direction with remote station alert system. Radar signal containing selected target simulations modulates an optical, infrared signal, in accordance with the selected target simulations. Radar target system is provided with selectively direct modulated IR radiation onto selected areas of an RF (Radar Frequency) array. Radar target identifier is selected with areas of the RF array function to add target angular simulations and target space position and scintillations to the other simulations contained in the radar signal. The IR radiation is converted to a radar frequency signal in the RF array and is transmitted to the radar test system. This Project basically has two phases: Parabolic antenna and ARM Processor (LPC2148). Firstly, a parabolic antenna is an antenna that uses a parabolic reflector, a curved surface with the cross-sectional shape of a parabola, to direct the radio waves. The most common form is shaped like a dish and is popularly called a dish antenna or parabolic dish. The main advantage of a parabolic antenna is that it has high directivity. Secondly, The LPC2148 microcontrollers are based on a 16-bit/32-bit ARM7TDMI-S CPU with real-time emulation and embedded trace support, that combine the microcontroller with embedded high-speed flash memory ranging from 32 KB to 512 KB. A 128-bit wide memory interface and unique accelerator architecture enable 32-bit code execution at the maximum clock rate.

The rest of the paper is organized as: Working Process is explained in Section [II], Basic Principle of Radar in Section [III], Conclusion in section [IV], Future Works in section [V], Applications in section [VI] and References in Section [VII].

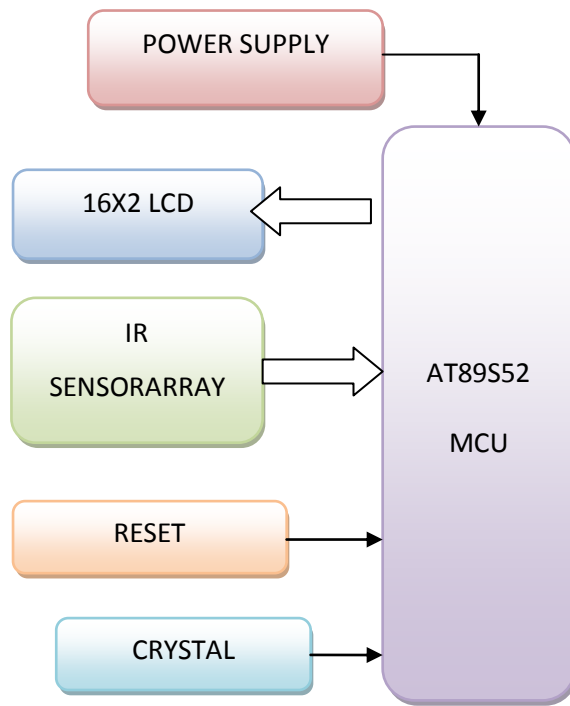

Figure1. RADAR TARGET IDENTIFIER

2. WORKING PROCESS:

Here, 30 volts AC supply is given to step down transformer which produces the output as 12 volts AC which is passed through the bridge rectifier. Rectifier output is pulsating DC that passes through the capacitive filter which blocks AC components and thus its output is DC that contains very less ripples, which is further given to 721 voltage regulator. The output of VR is constant DC. LED is used for power supply identification.

Here, two power supplies are being used: 3.3V and 5V power supplies. 5V is required to drive all the components of the circuit and 3.3V required for microcontroller. There is also an Antenna which consists of Transmitter and Receiver, and is used for transmitting and detecting the signal. The microcontroller contains drive Arm Processor chip LPC2148. It consists of 64 pins out of which 49 bits are inbuilt for the connector pins and 15 pins are input pins. It consists of Port0 and Port1 which is used for the connection purpose of

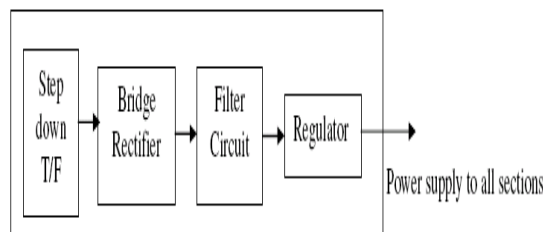

Figure2. POWER SUPPLY TRANSMISSION

Led and relay purpose and other sources. Relays help in the switching action of the microcontroller. It also consists of 16 bit TDMA mode processors with a CMOS battery and a Buzzer Switch. When we switch ‘ON’ the first source then the microcontroller is ‘ON’. When the first source is switched ON, the signal is started to be tracked and on the LCD the progress of data sending can be seen and this process is repeated whenever any source is switched ON. Reset Button is used to stop and reset the process from the initial source.

3. BASIC PRINCIPLE OF RADAR:

A radar system has a transmitter that emits radio waves called radar signal in predetermined directions. When these come into contact with an object, they are usually reflected or scattered in many directions. Radar signals are reflected especially well by materials of considerable electrical conductivity especially by most metals, by seawater and by wet ground. The radar signals that are reflected back towards the transmitter are the desirable ones that make radar works. If the object is moving either towards or away from transmitter, there is a slightly equivalent change in the frequency of the radio waves, caused by the Doppler Effect.

RADAR EQUATION:

The power P_{rec} , returning to the receiving antenna is given by the equation:

$$P_{rec} = \frac{P_t G^2 \lambda^2 \sigma}{(4\pi)^3 R_{max}^4} = \frac{P_t G^2 c^2 \sigma}{f_o^2 (4\pi)^3 R^4}$$

$$P_{rec} = P_t G^2 \left(\frac{\lambda}{4\pi R} \right)^2 \frac{\sigma}{4\pi R^2}$$

range loss loss due to
between transmit target reflection
antenna & target & range

Where

P_t =Transmitting Power

G = Gain Of the Transmitting Antenna

c = Effective Aperture of Receiving Antenna

σ = Radar Cross Section

$\lambda = (c/f)$ =Wavelength

R_{max} =Maximum Range of Radar

Our Project is based on the principle of **DOPPLER EFFECT**. Doppler Effect states that when the radar waves are sent towards a moving target or object, they are reflected back and received by the radar. If the frequency of the reflected wave is increased, it means that the target is moving towards the radar. If the frequency of the reflected wave is decreased, it means that the target is moving away from the radar.

In our project we are showing the detection of signal by using IR pair sensor. The principle behind infrared sensors is the transmission and reception of infrared light. An element known as a light emitting diode (LED) transmits active infrared light, which is reflected and received by an optical receiver known as a photo diode (PD). As long as there is no movement or object in the path of the light beam, the light pattern is static and the sensor remains in stand-by mode. When a person or object crosses the beam, the reflection of the light is distorted. This is registered by the PD, which gives off an impulse.

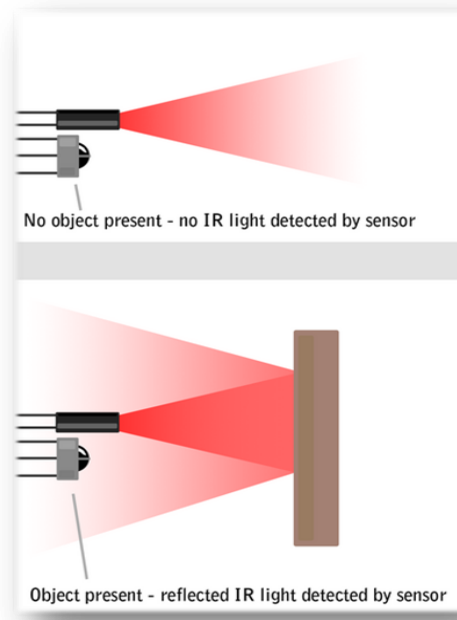

Figure3. IR effect when no object is present and when object is present

Sensors differ in the number of rows of active infrared spots. These spots are collectively referred to as the detection area.

4. CONCLUSION:

Mainly, in our project we have taken three sources which are used to produce IR signals. These IR signals are produced by the pair of a LED and a Photodiode. The principle behind infrared sensors is the transmission and receiving of infrared light. An element known as a light emitting diode (LED) transmits active infrared light, which is reflected and received by an optical receiver known as a photo diode (PD). As long as there is no movement or object in the path of the light beam, the light pattern is static and the sensor remains in stand-by mode. When a person or object crosses the beam, the reflection of the light is distorted. This is registered by the PD, which gives off an impulse. The Antenna movement is controlled by the Motor Driver L293D circuit. The motor driver IC is controlled by the signal which is coming from the input pin of the ARM Processor and this input pin is connected to the motor driver circuit by the help of a wire. The L293D is based on a principle of H Bridge circuit. An **H bridge** is an electronic circuit that enables a voltage to be applied across a load in either direction. These circuits are often used to allow DC motors to run forwards and backwards. Now, when the antenna rotates & any source comes in its path, it will detect the signal corresponding to particular frequency and produces a respective output. The prime objective of our project is signal detection which can be obtained by making the necessary connections and performing specific tasks as been explained in section [II].

5. FUTURE WORK:

ZigBee Module and Ultrasonic Sensors can be added to overcome the disadvantage of range. This project will use AT89S52 Microcontroller which is interfaced with Radar Target Identifier system and has an array of IR sensor pairs. These IR sensors are keeping track with the target in all the directions. If the target is found to be moved in any direction then it gives a control signal to the microcontroller and the status is displayed on the LCD for user identification. The distance will be displayed using Ultrasonic sensor. These signal transmissions will take place “wirelessly” between the master ZigBee attached to the transmitter section and the slave ZigBee attached to the receiver section. The ultrasonic sensor will be linked with IR Tx-Rx pair.

6. APPLICATIONS:

The information provided by radar includes the bearing and range of the object from the radar scanner. It is thus used in different fields where the need for such positioning is crucial.

1. It can be used for : to locate air, ground and sea targets. This evolved in the civilian field into applications for aircraft, ships and roads.
2. Marine radars are used to measure the bearing and distance of ships to prevent collision with other ships, to navigate and to fix their position.
3. Doppler Effect in radars helps in identification of weather of any regions.
4. RADAR is found on ships and boats for Collism avoidance.
5. RADARS may be used in law ebforcement and highway safety.
6. RADAR may also be used for remote sensing.

7. REFERENCES:

1. Penley, Bill, and Jonathan Penley, "Early Radar History – an introduction". 2002
2. Swords, Sean S., "Technical History of the beginnings of Radar", IEEE History of Technology Series, Vol. 6, London: Peter Peregrinus, 1986.
3. E. Fishler, A. Haimovich, R. Blum, D. Chizhik, L. Cimini, R. Valenzuela, "MIMO radar: an idea whose time has come", IEEE Radar Conference, 2004.
4. Mark R. Bell, "Information theory and radar waveform design." IEEE Transactions on Information Theory, 1993.
5. Grisenthwaite, Richard, "ARMv8-A Technology Preview". IEEE Conference, 2011.
6. Preeti Pannu, "Remote alignment of Dish Positioning by android application," IJERMT, vol. 2, no. 2, March 2015, pp. 267-269.